

FREEZER | Countertop Freezers

UPRIGHT FREEZER

RNG 50

CUSTOMIZATION AVAILABLE
PERSONALIZZAZIONE DISPONIBILE

60 mm	L2 -18°C -12°C	C ENERGY CLASS	3 +25°C/60RH
LED			GAS R290

DETAILS

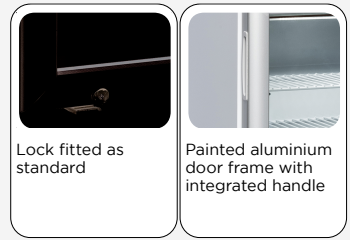

Lock fitted as standard

Painted aluminium door frame with integrated handle



GENERAL FEATURES

- 50 Lt. Upright freezer
- White coated steel for internal and external side
- Static Cooling
- Manual Defrost
- Foaming Agent Cyclopentane (60mm per side)
- Removable Gasket
- Interior LED light
- Triple heated safety tempered glass
- Self Closing Door
- Painted aluminium door frame with integrated handle
- Lock fitted as standard
- Adjustable shelves: 2 Pcs
- N.4 Adjustable feet
- Energy efficiency class: C

TECHNICAL SPECIFICATIONS

Capacity	50 L
Temperature	L2 (-12°C--18°C)
Consumption	2.53 kWh/24h
Rated Power	156 W
Noise level	45 dB(A)
Net Weight	40 Kg
Gross Weight	45 Kg
External Dimensions (WxDxH mm)	570x535x530
Internal Dimensions (WxDxH mm)	450x420x380
Packaging dimensions (WxDxH mm)	610x580x580
Loading quantities 20'/40'/40'HQ	144/304/304

PRODUCT DIMENSIONS

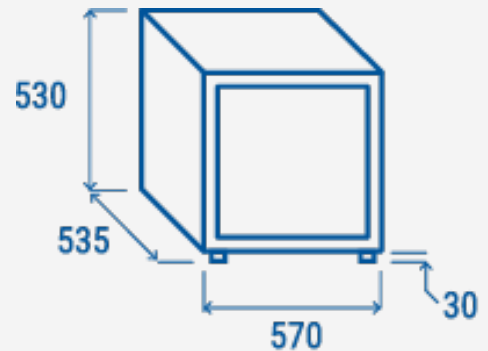

CERTIFICATION

CE RoHS

